

**Lesson A** *Listening*

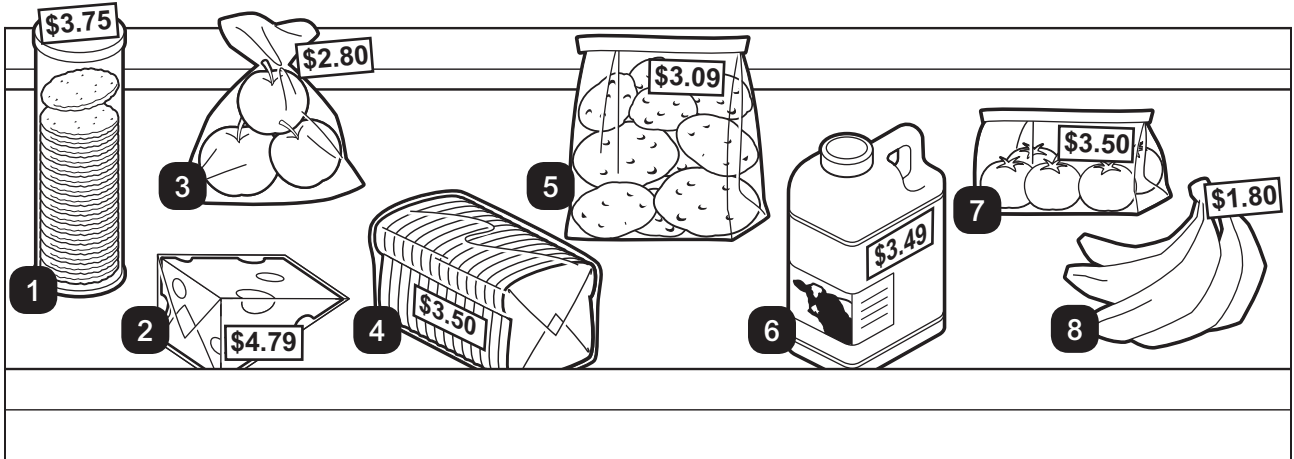

**A** Look at the picture. Write the words.

apples	bread	cookies	potatoes
bananas	cheese	milk	tomatoes



- |                  |            |
|------------------|------------|
| 1. c o o k i e s | 5. p _____ |
| 2. c _____       | 6. m _____ |
| 3. a _____       | 7. t _____ |
| 4. b _____       | 8. b _____ |

**B** Complete the shopping lists. Write the totals.

Food	Price
bananas	\$ 1.80
cookies	\$ 3.75
milk	\$ 3.49
bread	\$ 3.50
<b>Total</b>	<b>\$ _____</b>

Food	Price
potatoes	\$ 3.09
apples	\$ 2.80
cheese	\$ 4.79
tomatoes	\$ 3.50
<b>Total</b>	<b>\$ _____</b>

**C** Write your shopping list for this weekend.

\_\_\_\_\_

\_\_\_\_\_

\_\_\_\_\_



**Lesson A** *Listening*

**A** Look at the picture. Write the words.

apples	bread	cookies	potatoes
bananas	cheese	milk	tomatoes

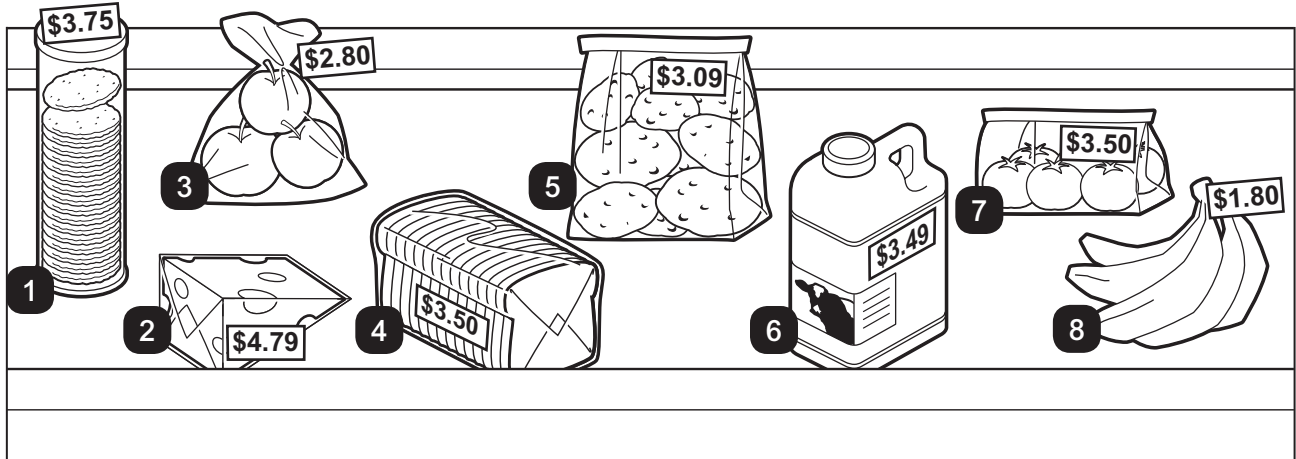

- |                   |          |
|-------------------|----------|
| 1. <u>cookies</u> | 5. _____ |
| 2. _____          | 6. _____ |
| 3. _____          | 7. _____ |
| 4. _____          | 8. _____ |

**B** Look at the picture in Exercise A. Complete the shopping lists. Write the totals.

Food	Price
bananas	\$ <u>1.80</u>
cookies	\$ _____
milk	\$ _____
bread	\$ _____
<b>Total</b>	\$ _____

Food	Price
potatoes	\$ <u>3.09</u>
apples	\$ _____
cheese	\$ _____
tomatoes	\$ _____
<b>Total</b>	\$ _____

**C** Write your shopping list for this weekend.

\_\_\_\_\_

\_\_\_\_\_

\_\_\_\_\_

**Lesson A** *Listening*



**A** Look at the picture. Write the words.

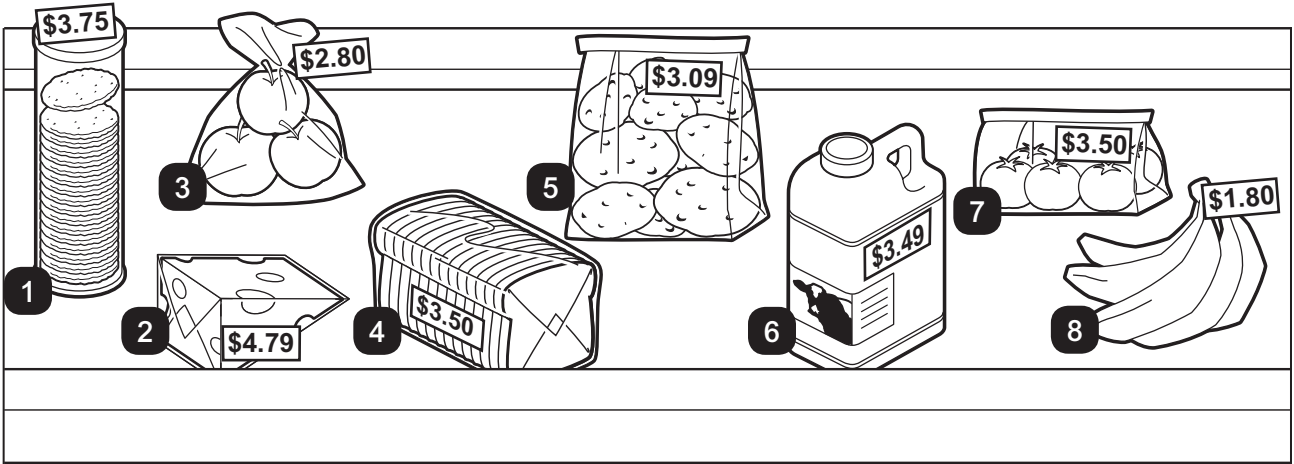

- |                         |          |
|-------------------------|----------|
| 1. <u>cookies</u> _____ | 5. _____ |
| 2. _____                | 6. _____ |
| 3. _____                | 7. _____ |
| 4. _____                | 8. _____ |

**B** Look at the picture in Exercise A. Complete the shopping lists. Write the totals.

Food	Price
<u>bananas</u>	\$ 1.80
cookies	\$ _____
_____	\$ 3.49
bread	\$ _____
<b>Total</b>	<b>\$ _____</b>

Food	Price
potatoes	\$ _____
_____	\$ 2.80
cheese	\$ _____
_____	\$ 3.50
<b>Total</b>	<b>\$ _____</b>

**C** Write your shopping list for this weekend.

_____	_____
_____	_____
_____	_____
_____	_____



# Lesson B How many? How much?

**A** Complete the charts.

Singular	Plural
apple	a p p l e s
orange	_____

Singular	Plural
onion	_____
pie	_____

**B** Complete the chart.

apples	cheese	milk	pies
carrots	juice	onions	rice

Count nouns	Non-count nouns
a a p p l e s      o _____	c _____      m _____
c _____      p _____	j _____      r _____

**C** Look at the ingredients. Complete the questions. Use *many* or *much*.

- A** How many carrots do I need?  
**B** You need four carrots.
- A** How \_\_\_\_\_ orange juice do I need?  
**B** You need one cup of orange juice.
- A** How \_\_\_\_\_ apples do I need?  
**B** You need three apples.
- A** How \_\_\_\_\_ sugar do I need?  
**B** You need one tablespoon of sugar.

### SUMMER SALAD RECIPE



#### INGREDIENTS

- |           |                       |
|-----------|-----------------------|
| 4 carrots | 1 cup of orange juice |
| 3 apples  | 1 tablespoon of sugar |

**D** Think of a recipe. Write the ingredients.

<b>Name of recipe:</b>
Ingredients:

**Lesson B**

**How many? How much?**



**A** Complete the charts.

Singular	Plural
apple	<i>apples</i>
orange	

Singular	Plural
onion	
pie	

**B** Complete the chart.

apples	cheese	milk	pies
carrots	juice	onions	rice

Count nouns	Non-count nouns
<i>apples</i> _____	_____
_____	_____

**C** Look at the ingredients. Write questions.

- A** How many carrots do I need?

**B** You need four carrots.
- A** \_\_\_\_\_?

**B** You need one cup of orange juice.
- A** \_\_\_\_\_?

**B** You need three apples.
- A** \_\_\_\_\_?

**B** You need one tablespoon of sugar.

**SUMMER SALAD RECIPE**



**INGREDIENTS**

- 4 carrots      1 cup of orange juice  
 3 apples      1 tablespoon of sugar

**D** Think of a recipe. Write the ingredients.

<b>Name of recipe:</b>
Ingredients:



# Lesson B How many? How much?

**A** Complete the charts.

Singular	Plural
apple	<i>apples</i>
orange	
onion	

Singular	Plural
pie	
peach	
cherry	

**B** Complete the word maps.

apples    carrots    cheese    juice    milk    onions    pies    rice

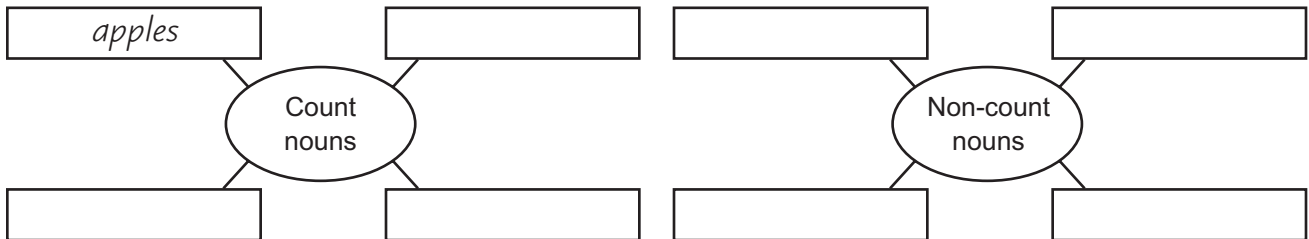

**C** Look at the ingredients. Write questions and complete the answers.

- A** *How many carrots do I need* ?

**B** *You need four* \_\_\_\_\_ carrots.
- A** \_\_\_\_\_ ?

**B** \_\_\_\_\_ of orange juice.
- A** \_\_\_\_\_ ?

**B** \_\_\_\_\_ apples.
- A** \_\_\_\_\_ ?

**B** \_\_\_\_\_ of sugar.

### SUMMER SALAD RECIPE



#### INGREDIENTS

- 4 carrots      1 cup of orange juice  
3 apples      1 tablespoon of sugar

**D** Think of a recipe. Write the ingredients.

<b>Name of recipe:</b>
Ingredients: